

CUSTOMER: Ropla
DISTRIBUTOR:
(PE48AA1)

NO.: TC79006(1)

APPROVE SHEET
[Compliance with RoHS]

PRODUCT: DC BRUSHLESS FAN

USER P/N: _____

Parts No.: JF0825B1M-006-065RP5

Printed model number on the stick: JF0825B1M-PR

(SIGNATURE)

JAMICON GROUP
KAIMEI ELECTRONIC CORP.

	CHECKER	DESIGNER

CUSTOMER: Ropla
DISTRIBUTOR:
(PE48AA1)

NO.: TC79006(1)

APPROVE SHEET

[Compliance with RoHS]

PRODUCT: DC BRUSHLESS FAN

USER P/N: _____

Parts No.: JF0825B1M-006-065RP5

Printed model number on the stick: JF0825B1M-PR

(SIGNATURE)

JAMICON GROUP
KAIMEI ELECTRONIC CORP.

	CHECKER	DESIGNER
		

1. MECHANICAL:

1-01	Dimension	Dimension of fan shall be shown in the outline styling drawing attached.
1-02	Motor	Four-pole motor.
1-03	Frame	Plastic material UL 94V-0 (P.B.T).
1-04	Impeller	Plastic material UL 94V-0 (P.B.T).
1-05	Free drop shock	In minute package condition, the fan should withstand each one drop of three faces from 30cm distance height onto 10 mm thickness of wooden board.

2.ELECTRICAL:

2-01	Rated current	Rated current shall be measured after 30 minutes continuous rotation at rated voltage.
2-02	Start voltage	The voltage that enable to start the fan by sudden switch on.
2-03	Rated Speed	Rated speed shall be measured after 30 minutes continuous rotation at rated voltage.
2-04	Input Power	Input power shall be measured after 30 minutes continuous rotation at rated voltage.
2-05	Lock Current	Locked current shall be measured Within one minute at rotor locked, after 30 minutes continuous rotation at rated voltage in clear air.
2-06	Insulation resistance	More than 10M ohm at 500 V.D.C between lead and housing.
2-07	Dielectric strength	Measured 5 mA(max) trip current at 700 V.A.C for 3 sec. between lead and housing.
2-08	Locked motor protection	Designed to meet UL, CUL and TUV.

3.CHARACTERISTICS:

3-01	Air Flow & Static Pressure	The air flow data and static pressures should be determined in accordance with AMCA standard or DIM 24163 specification in a double- chamber testing with intake-side measurement.
3-02	Noise level	The measurement of noise level is carried out with reference to DIM 45635 in an echoic chamber with the microphone positioned 1 M from the air intake. Testing fan shall be hung in clean air.

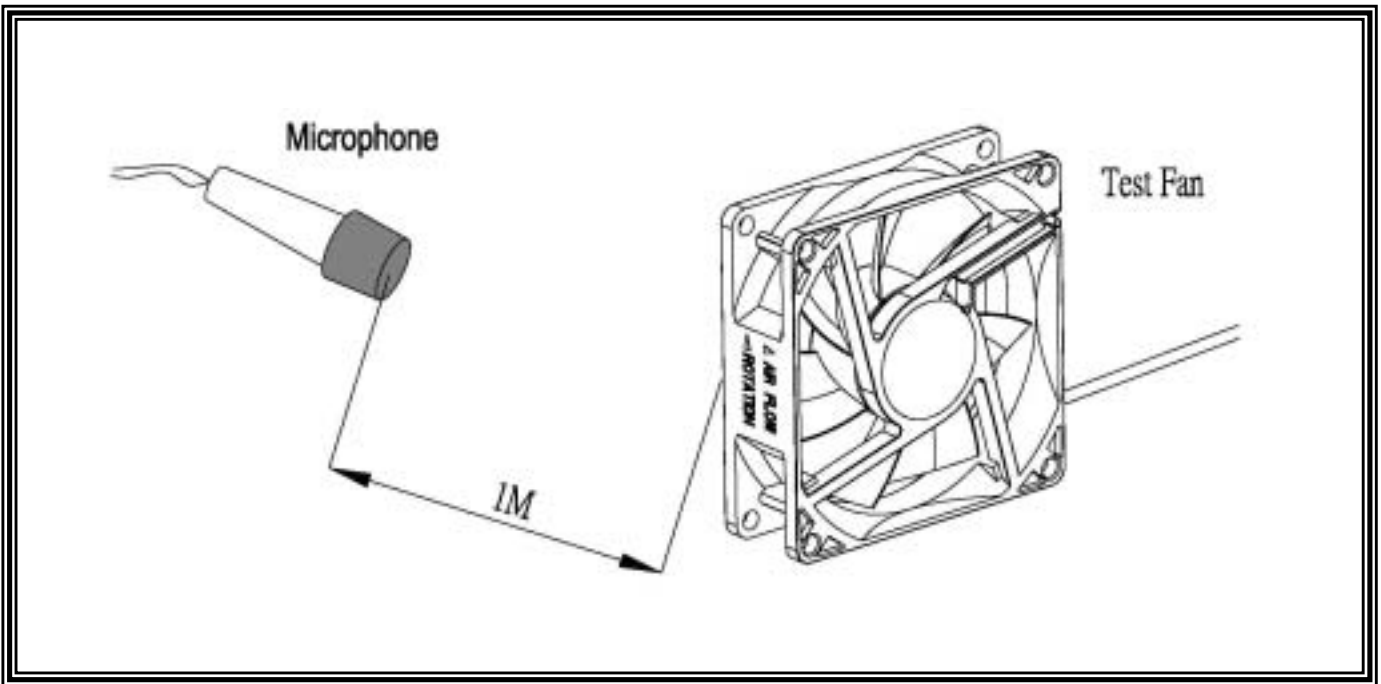

4.ENVIRONMENTAL:

4-01	Operating temperature	-10 to 70 (ordinary humidity)
4-02	Storage Temperature	-40 to 70 (ordinary humidity)
4-03	Humidity	After 96 hrs, 95% RH 40±2 per MIL-STD-202F method 103B, Humidity test , The measured data of insulation resistance & dielectric strength should meet the specification listed in attach.
4-04	Thermal Shock	After thermal shock test per MIL-STD-202F method 107D, Condition D, The measured data of insulation resistance & dielectric strength should the specification

5.DATA-SHEET:**MODEL JF0825B1M-006-065RP5****5-1. SPECIFICATION:**

NO.	ITEM	SPECIFICATION	UNIT	CONDITION
5-1-01	Dimension	80*80*25	mm	-----
5-1-02	Bearing	Dual Ball	-----	-----
5-1-03	Rated Voltage	12.0	VDC	-----
5-1-04	Operating Voltage	10.2 ~ 13.8	VDC	-----
5-1-05	Start Voltage	6	VDC	On/off test
5-1-06	Speed	2500	R.P.M	±10%,At rated Voltage
5-1-07	Input Current	0.08	Amp	At rated Voltage
5-1-08	Input Power	0.96	Watt	At rated Voltage
5-1-09	Nominal Current	0.15	Amp	At rated Voltage
5-1-10	Air Flow	32.52	CFM	At 0 static Pressure of rated speed
5-1-11	Static Pressure	0.099	inchH ₂ O	At 0 air flow of rated speed
5-1-12	Noise	27.8	dBA	At rated speed
5-1-13	Life Expectancy	50,000	Hours	At 25 &RH65%
5-1-14	Motor protection	Impedance protected		
5-1-15	Polarity protection	It will not damage the fan while reverse input.		
5-1-16	Auto Restart	NO	-----	-----
5-1-17	Speed Signal output	NO	-----	-----
5-1-18	Alarm Signal output	NO	-----	-----
5-1-19	Rotation direction	From the label side	-----	Clockwise
5-1-20	Weight	80	Gram	Per each piece
5-1-21	Safety Certificate	UL, CUL, TUV, CE	-----	-----
5-1-22	IP Rating	IP55		

5-2. LEAD WIRE:

NO.	ITEM	CONDITION			
5-2-01	AWG NO. & Authorize	24AWG, UL1007			
5-2-02	Color				
		Black	Red		
5-2-03	Line Length	260±10mm			
5-2-04	Connector	Notes as: Not included in this lead wire.			
5-2-05	Tube	NO			

JAMICON FAN PERFORMANCE CURVES

Air Flow (CMM) (M³/m)

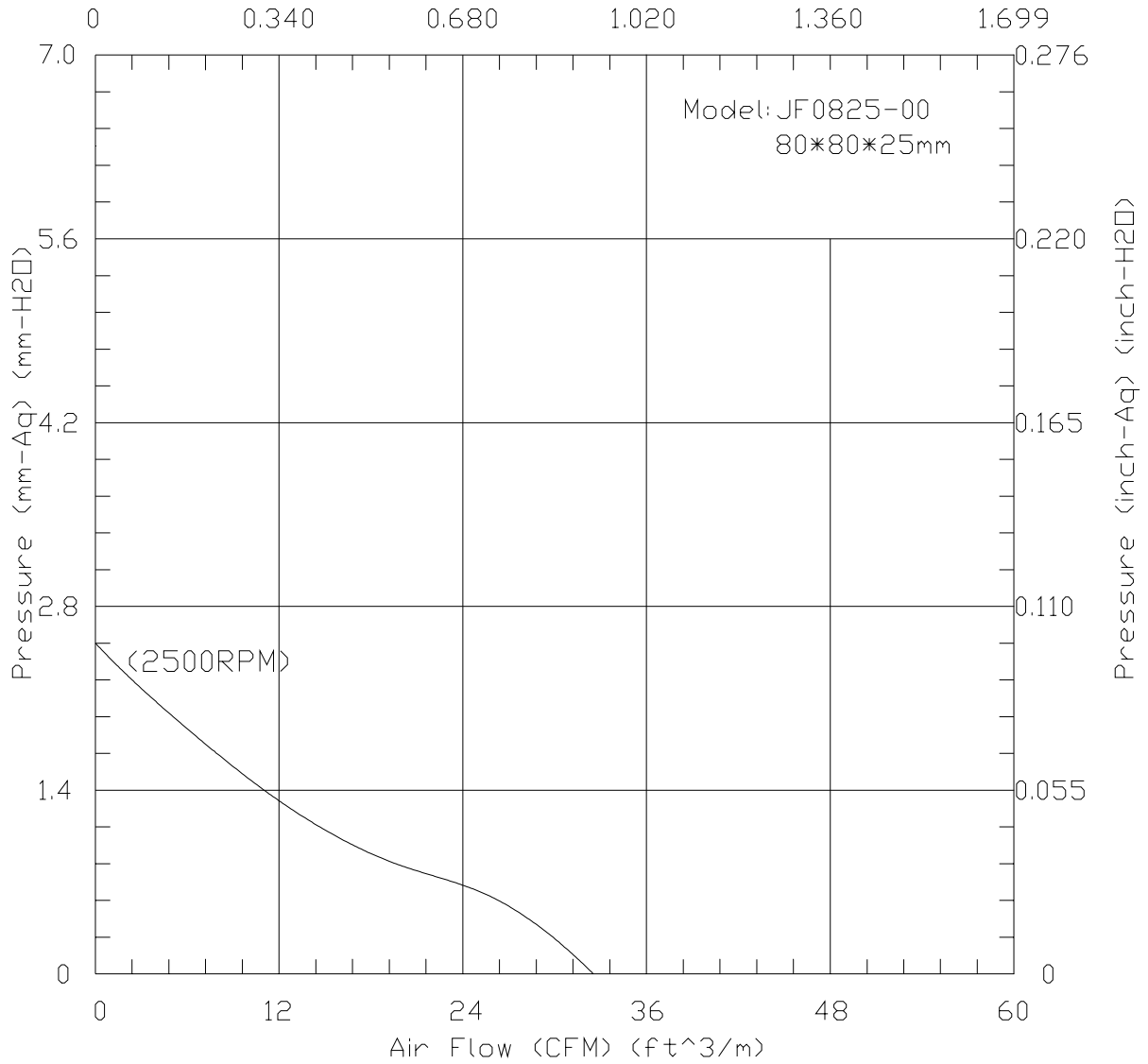

風扇振動噪音性能測試報告

(The Test Report of Fan Vibration and Noise)

風扇型號(Sample Type): JF0825B1M
 基本規格(Properties): DC 12V 7葉 4極 2500RPM

測試日期(Test Date): 2002/10/1 PM 06:21:51
 測試編號(Test No.): (1)

測試條件(Test Conditions)

輸入電壓(Input Voltage): 12 V
 量測時間(Measuring Time): 20 sec
 麥克風距離(Mic. Distance): 100 cm
 麥克風角度(Mic. Angle): 180°
 頻域加權(Freq. Weighting): A
 時域加權(Time Weighting): SLOW
 背景噪音(Background Noise): 15.0 dB(A)
 溫度(Temperature): ℃
 相對濕度(Relative Humidity): %

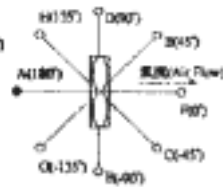

測試結果(Test Results)

電壓(Passing Voltage):
 電流(Electric Current):
 消耗功率(Power Dissipation):
 轉速(Rotation Speed): 2508 RPM
 振動量(Vibration Level) (依據 ISO 10816-1)
 振動速度(Vib. Velocity): 1.31 mm/sec RMS
 均態聲壓位準(Time-averaged SPL_{Leq}) (依據 CNS 8753)
 監視點(A: Mens. Point): 28.0 dB(A)
 1 米處(A: 1m Point): 27.8 dB(A)
 最大聲壓位準(MaxL): 28.5 dB(A)
 最小聲壓位準(MinL): 25.9 dB(A)

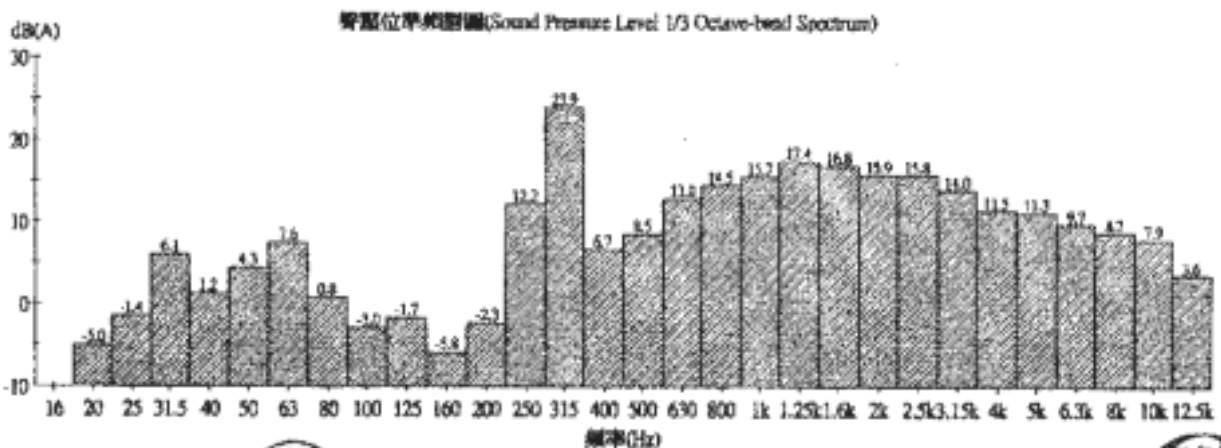
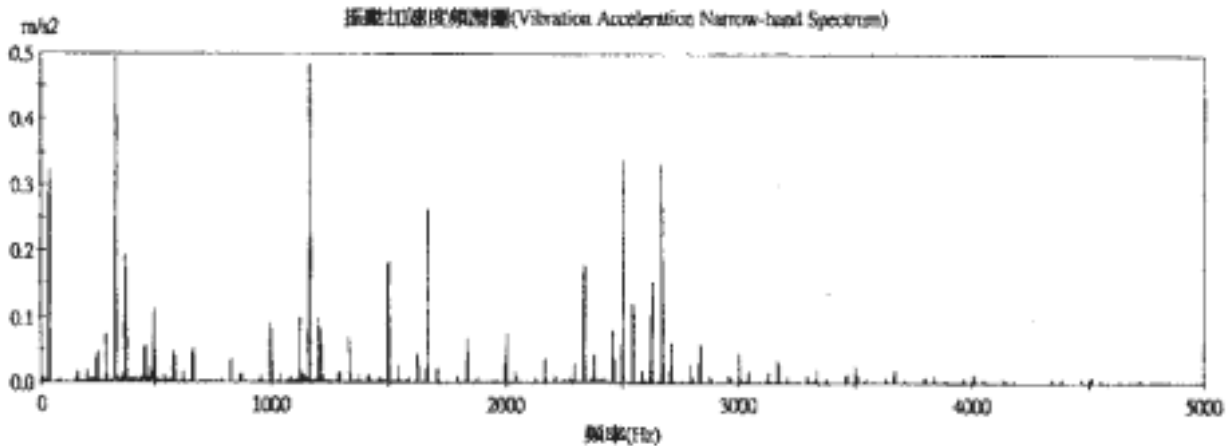

簽核人員(Signatory): 

操作員(Operator): YUNGCHIH 簽章(Signature): 

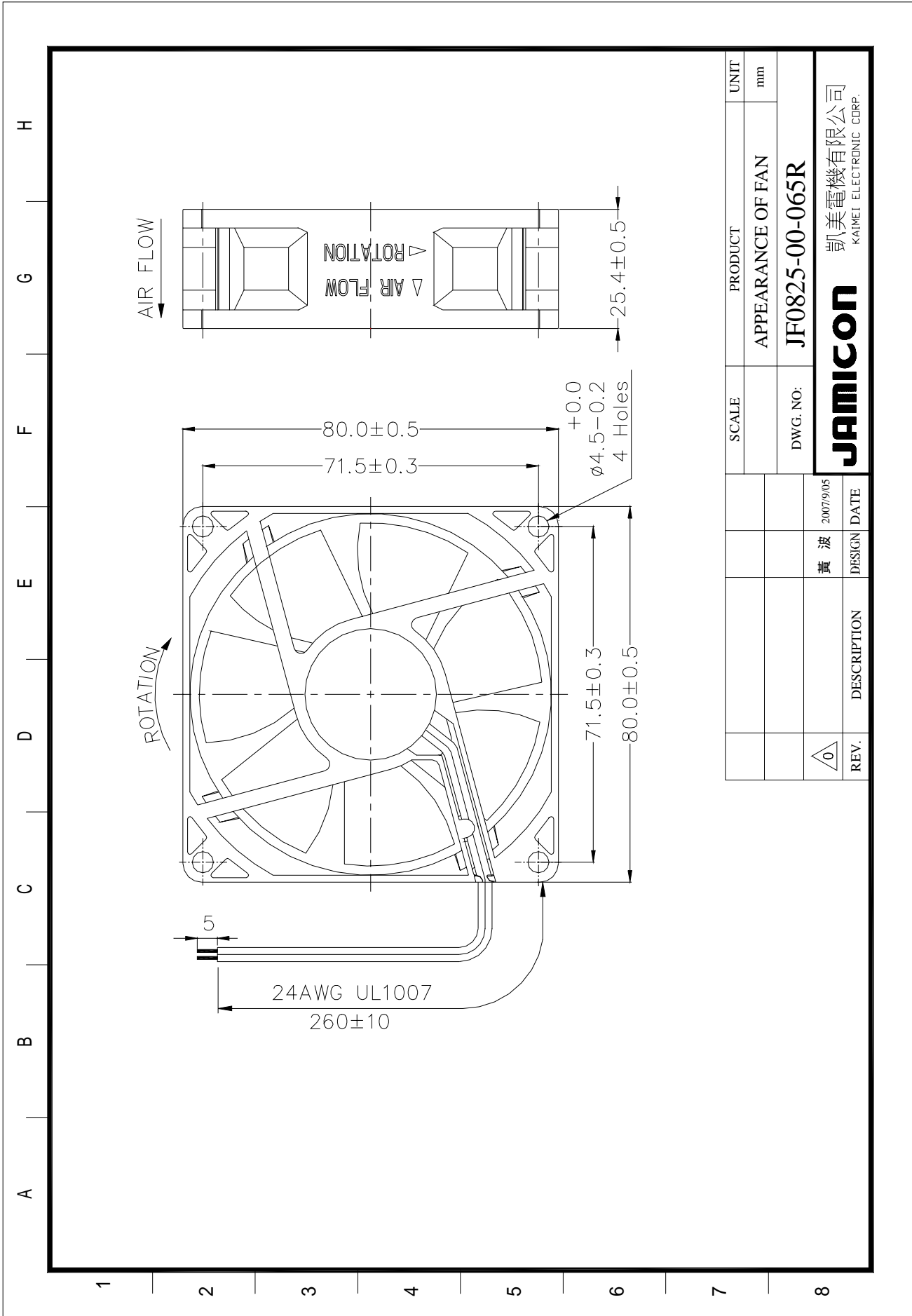

SCALE	PRODUCT	UNIT
	APPEARANCE OF FAN	mm
DWG. NO:	JF0825-00-065R	
REV.	DESCRIPTION	DESIGN DATE
0		2007/9/05
		黄波

JAMICON
 凱美電機有限公司
 KAIMEI ELECTRONIC CORP.



GPWV2.E156480
Fans, Electric - Component

Page Bottom

Fans, Electric - Component

See General Information for Fans, Electric - Component

KAIMEI ELECTRONIC CORP

E156480

131H

81 HSIN-TAI-WU RD, SEC 1

HSICHIH, TAIPEI HSI-FN 221 TAIWAN

AC fans, Models JA1203811XX, JA1203822XX, where XX is any character; Model JA1738 followed by H2 or H1; Model JA1238 followed by M2, M1, L2 or L1; Model JA1225 followed by L2 or L1; Models JA0825H1(X1)(X2)(X3), JA0825H2(X1)(X2)(X3), JA0838H1(X1)(X2)(X3), JA0838H2(X1)(X2)(X3), JA0925H1(X1)(X2)(X3), JA0925H2(X1)(X2)(X3), JA1225H1(X1)(X2)(X3), JA1225H2(X1)(X2)(X3), JA1225L1(X1)(X2)(X3), JA1225L2(X1)(X2)(X3), JA1238H1(X1)(X2)(X3), JA1238H2(X1)(X2)(X3), JA1238M1(X1)(X2)(X3), JA1238M2(X1)(X2)(X3), JA1238L1(X1)(X2)(X3), JA1238L2(X1)(X2)(X3), JA1738H1(X1)(X2)(X3), JA1738H2(X1)(X2)(X3), JA1751H1(X1)(X2)(X3), JA1751H2(X1)(X2)(X3), JA0938H1(X1)(X2)(X3), JA0938H2(X1)(X2)(X3), JA2589H1(X1)(X2)(X3), JA2589H2(X1)(X2)(X3), JA1538H1(X1)(X2)(X3), JA1538H2(X1)(X2)(X3), JA1538M1(X1)(X2)(X3), JA1538M2(X1)(X2)(X3), JA1538L1(X1)(X2)(X3), JA1538L2(X1)(X2)(X3), LA1238H1(X1)(X2)(X3), LA1238H2(X1)(X2)(X3), LA1238M1(X1)(X2)(X3), LA1238M2(X1)(X2)(X3), LA1238L1(X1)(X2)(X3), LA1238L2(X1)(X2)(X3), LA0925H1(X1)(X2)(X3), LA0925H2(X1)(X2)(X3), LA0825H1(X1)(X2)(X3), LA0825H2(X1)(X2)(X3), where (X1), (X2), (X3) may be 0 thru 9, A thru Z, "-" or blank.

Models MA0825H2Bzz, MA0825H2Szz, MA0825M2Bzz, MA0825M2Szz, MA0838H2Bzz, MA0838H2Szz, MA0838M2Bzz, MA0838M2Szz, MA0925H2Bzz, MA0925H2Szz, MA0925M2Bzz, MA0925M2Szz, MA0938H2Bzz, MA0938H2Szz, MA0938M2Bzz, MA0938M2Szz, KA0938H2Bzz, KA0938H2Szz, KA0938M2Bzz, KA0938M2Szz, MA1225H2Bzz, MA1225H2Szz, MA1225M2Bzz, MA1225M2Szz, KA1338H2Bzz, KA1338H2Szz, KA1338M2Bzz, KA1338M2Szz, KA1338L2Bzz, KA1338L2Szz, MA1338H2Bzz, MA1338H2Szz, MA1338M2Bzz, MA1338M2Szz, MA2260H2Bzz, MA0825H1Bzz, MA0825M1Bzz, MA0825M1Szz, MA0838H1Bzz, MA0838H1Szz, MA0838M1Bzz, MA0838M1Szz, MA0925H1Bzz, MA0925H1Szz, MA0925M1Bzz, MA0925M1Szz, MA0938H1Bzz, MA0938H1Szz, MA0938M1Bzz, MA0938M1Szz, KA0938H1Bzz, KA0938H1Szz, KA0938M1Bzz, KA0938M1Szz, MA1225H1Bzz, MA1225H1Szz, MA1225M1Bzz, MA1225M1Szz, KA1338H1Bzz, KA1338H1Szz, KA1338M1Bzz, KA1338M1Szz, MA2260H1Bzz.

Models JA1751H1, JA1751H2, JA1238H1, JA1238H2, JA1238-1H1, JA1238-1H2, JA1225H1, JA1225H2, JA0925H1, JA0925H2, JA0838H1, JA0838H2, JA0825H1, JA0825H2.

Model KAX (A) (B) X₁ and/or X₂, where X may be 0825, 0838, 0925, 1225, 1238 or 1751, (A) may be H1, H2, M1, M2, L1 or L2, (B) may be B or S and X₁, X₂ may be 0 thru 9, A thru Z, blank or "-"; Model MAX (A) (B) X₁ and/or X₂, where X may be 1238, 1538, 1738, 1751, 1755 or 2589, (A) may be H1, H2, M1 or M2, (B) may be B, S and X₁, X₂ may be 0 thru 9, A thru Z or "-".

DC fans Models JF0207, JF0307, JF0407 followed by B or S, followed by -1HX, -1LX, -1MX, -5HX, -5LM or -5MX; Model JF0210 followed by B, C or S, followed by -5LXXX; Model JF0410 followed by B, C or S, followed by -1XXX, -1MXXX, -1HXXX or -5MXXX; Model JF0413 followed by B, C, H, F or S, followed by -1MXXX or -1HXXX; Model JF0512 followed by B, C or S, followed by 1LXXX or -1MXXX; Model JF0615 followed by B, C or S, followed by -1HXXX, -1LXXX or -1MXXX, -1EXXX, -1VXXX; Model JF0620 followed by B, C, H, F or S, followed by 1VXXX, -1EXXX, 1LXXX, -1MXXX, -1HXXX, -2VXXX, 2EXXX, -2LXXX, -2HXXX or -2MXXX; Model JF0625 followed by B, C, H, F or S, followed by -1VXXX, -1EXXX, -1LXXX, -1MXXX, 1HXXX, -2VXXX, -2EXXX, -2LXXX, -2MXXX or -2HXXX; Model JF0825 followed by B, C or S, followed by -1EXXX, -1LXXX, -1MXXX, -1HXXX, -2EXXX, -2LXXX, -2MXXX or -2HXXX; where "X" may be 0 thru 9, A thru Z, "-" or blank; Model JF0925 followed by B, C or S, followed by 1EXXX, -1LXXX, -1MXXX, -1HXXX, 2EXXX, -2LXXX, -2MXXX or -2HXXX; Model JF1225 followed by B, C or S, followed by -1EXXX -1LXXX, -1MXXX, 1HXXX, -2EXXX, -2LXXX, -2MXXX or -2HXXX; Model JF0410S1.

Models JF0210, JF0410, JF0510 followed by B or S, may be followed by 1H, 1M, 1L, 5L, 5M.

Model JF0615(X)2(Y)XXX, where (X) may be S, B or C and (Y) may be H, M, L, F or V.

Models JF0210(X)1H(Y), JF0210(X)1M(Y), JF0210(X)5H(Y), JF0210(X)5L(Y), JF0210(X)5M(Y), where (X) may be B, C or S and (Y) may be 0 thru 9, A thru Z or blank.

Models JF0310(X)1H(Y), JF0310(X)1L(Y), JF0310(X)1M(Y), JF0310(X)5H(Y), JF0310(X)5L(Y), JF0310(X)5M(Y), where (X) may

Models JF0A08(X)5H(Y), JF0A08(X)5L(Y), JF0A08(X)5M(Y), where (X) may be B, C or S and (Y) may be 0 thru 9, A thru Z or blank.

Models JF0B10(X)1H(Y), JF0B10(X)1L(Y), JF0B10(X)1M(Y), JF0B10(X)5H(Y), JF0B10(X)5L(Y), JF0B10(X)5M(Y), where (X) may be B, C or S and (Y) may be 0 thru 9, A thru Z or blank.

Models JF1751(X)4S(Y), where (X) may be B, C or S and (Y) may be 0 thru 9, A thru Z or blank.

Model JF1751(X)4S(Y), where (X) may be B, C or S and (Y) may be 0 thru 9, A thru Z or blank.

Models KF0210S5L, KF0210S5M, KF0210S5H, KF0210B5L, KF0210B5M, KF0210B5H, KF0210B5LD, KF0210B5MD, KF0210B5HD, KF0310S5L, KF0310S5M, KF0310S5H, KF0310B5L, KF0310B5M, KF0310B5H, KF0310B5LD, KF0310B5MD, KF0310B5HD, KF0410S5L, KF0410S5M, KF0410S5H, KF0410B5L, KF0410B5M, KF0410B5H, KF0410B5LD, KF0410B5MD, KF0410B5HD, KF0306S1M, KF0306S1H, KF0306B1M, KF0306B1H, KF0406S1M, KF0406S1H, KF0406B1M, KF0406B1H, KF0409S1M, KF0409S1H, KF0409B1M, KF0409B1H, KF0409B1LD, KF0409B1MD, KF0409B1HD, KF0510S1L, KF0510S1M, KF0510S1H, KF0510B1L, KF0510B1M, KF0510B1H, KF0510B1LD, KF0510B1MD, KF0510B1HD, KB3508S1M, KB3508S1H, KB3508B1M, KB3508B1H, KB4509S1M, KB4509S1H, KB4509B1M, KB4509B1H, KF0410B5M, KF0410B5H, KF0410B5LD, KF0410B5MD, KF0410B5HD, KF0306S5M, KF0306S5H, KF0306B5M, KF0306B5H, KF0406S5M, KF0406S5H, KF0406B5M, KF0406B5H, KF0409S5M, KF0409S5H, KF0409B5M, KF0409B5H, KF0409B5LD, KF0409B5MD, KF0409B5HD, KF0509S5M, KF0509S5H, KF0509B5M, KF0509B5H, KF0509B5LD, KF0509B5MD, KF0509B5HD, KB3508S5M, KB3508S5H, KB3508B5M, KB3508B5H, KB4509S5M, KB4509S5H, KB4509B5M, KB4509B5H, KF0210S1L, KF0210S1M, KF0210S1H, KF0210B1L, KF0210B1M, KF0210B1H, KF0210H5L, KF0210H5M, KF0210H5H, KF0210F5L, KF0210F5M, KF0210F5H, KF0210H1L, KF0210H1M, KF0210H1H, KF0210F1L, KF0210F1M, KF0210F1H, KF0310H5L, KF0310H5M, KF0310H5H, KF0310F5L, KF0310F5M, KF0310F5H, KF0310H1L, KF0310H1M, KF0310H1H, KF0310F1L, KF0310F1M, KF0310F1H, KF0410H5L, KF0410H5M, KF0410H5H, KF0410F5L, KF0410F5M, KF0410F5H, KF0510C1H, KF0510H1L, KF0510H1M, KF0510H1H, KF0510F1L, KF0510F1M, KF0510F1H. All models may have optional suffix "x4x5x6", where "x4", "x5", and "x6" may be A Z, 0 9, "-" or blank.

Model KF0xyz, where x may be 420, 515 or 610, y may be B1, B2, B5, S1, S2 or S5 and z may be H, HC, HD, HS, L, LC, LD, LS, M, MC, MD or MS; Model KF123xyz, where x may be 2 or 8, y may be B1, B2, B5, S1, S2 or S4 and z may be H, HA, L, LA, M or MA; Model MF0xyz, where x may be 410 or 510, y may be B1, B5, S1 or S5 and z may be H, HC, HD, HS, L, LC, LD, LS, M, MC, MD or MS.

Models KF0210S5L, KF0210S5M, KF0210S5H, KF0210B5L, KF0210B5M, KF0210B5H, KF0210C5L, KF0210C5M, KF0210C5H, KF0210S1L, KF0210S1M, KF0210S1H, KF0210B1L, KF0210B1M, KF0210B1H, KF0210C1L, KF0210C1M, KF0210C1H, KF0310S5L, KF0310S5M, KF0310S5H, KF0310B5L, KF0310B5M, KF0310B5H, KF0310C5L, KF0310C5M, KF0310C5H, KF0310S1L, KF0310S1M, KF0310S1H, KF0310B1L, KF0310B1M, KF0310B1H, KF0310C1L, KF0310C1M, KF0310C1H, KF0410S5L, KF0410S5M, KF0410S5H, KF0410B5L, KF0410B5M, KF0410B5H, KF0410C5L, KF0410C5M, KF0410C5H, KF0410S1L, KF0410S1M, KF0410S1H, KF0410B1L, KF0410B1M, KF0410B1H, KF0410C1L, KF0410C1M, KF0410C1H, KF0410S5L, KF0410S5M, KF0410S5H, KF0410B5L, KF0410B5M, KF0410B5H, KF0410C5L, KF0410C5M, KF0410C5H, KF0510S5L, KF0510S5M, KF0510S5H, KF0510B5L, KF0510B5M, KF0510B5H, KF0510C5L, KF0510C5M, KF0510C5H. All models may have optional suffix "x4x5x6", where "x4", "x5" and "x6" may be A thru Z, 0 thru 9, "-" or blank.

Models KF0306S1M, KF0306S1H, KF0306C1H, KF0306C1S, KF0306S5M, KF0306S5H, KF0306C5M, KF0306C5H, KF0409S1L, KF0409S1M, KF0409S1H, KF0409B1L, KF0409B1M, KF0409B1H, KF0409C1L, KF0409C1M, KF0409C1H, KF0409S5L, KF0409S5M, KF0409S5H, KF0409B5L, KF0409B5M, KF0409B5H, KF0409C5L, KF0409C5M, KF0409C5H, KF0509S5L, KF0509S5M, KF0509S5H, KF0509B5L, KF0509B5M, KF0509B5H, KF0509C5L, KF0509C5M, KF0509C5H. All models may have optional suffix "x4x5x6", where "x4", "x5" and "x6" may be A thru Z, 0 thru 9, "-" or blank.

Models KF0510S5L, KF0510S5M, KF0510S5H, KF0510C5L, KF0510C5M, KF0510C5H, KF0510B5L, KF0510B5M, KF0510B5H, KF0515S5L, KF0515S5M, KF0515S5H, KF0515C5L, KF0515C5M, KF0515C5H, KF0515B5L, KF0515B5M, KF0515B5H, KF0509B1L, KF0509B1M, KF0509B1H, KF0509S1L, KF0509S1M, KF0509C1L, KF0509C1M, KF0509C1H, KF0515S1L, KF0515S1M, KF0515S1H, KF0515C1L, KF0515C1M, KF0515C1H, KF0515B1L, KF0515B1M, KF0515B1H, KF0625S1L, KF0625S1M, KF0625S1H, KF0625C1L, KF0625C1M, KF0625C1H, KF0625B1L, KF0625B1M, KF0625B1H, KF0510F5L, KF0510F5M, KF0510F5H, KF0510H5L, KF0510H5M, KF0510H5H. All models may have optional suffix "x4x5x6", where "x4", "x5" and "x6" may be A thru Z, 0 thru 9, "-" or blank.

Models KF0407C1H, KF0407S1H, KF0407C1M, KF0407S1M, KF0407C5H, KF0407S5H, KF0407C5M, KF0407S5M, KF0C07C1H, KF0C07S1H, KF0C07C1M, KF0C07S1M, KF0C07C5H, KF0C07S5H, KF0C07C5M, KF0C07S5M, KF0420B1L, KF0420S1L, KF0420B1M, KF0420S1M, KF0420B1H, KF0420S1H, KF0420B5L, KF0420S5L, KF0420B5M, KF0420S5M, KF0420B5H, KF0420S5H, KF0610S1H, KF0610C1H, KF0610B1H, KF0610C1M, KF0610B1M, KF0610S1M, KF0610C1L, KF0610B1L, KF0610S1L, KF0420C1L, KF0420H1L, KF0420F1L, KF0420C1M, KF0420H1M, KF0420F1M, KF0420C1H, KF0420H1H, KF0420F1H, KF0420C5L, KF0420H5L, KF0420F5L, KF0420C5M, KF0420H5M, KF0420F5M, KF0420C5H, KF0420H5H, KF0420F5H, KF0610H1H, KF0610H1M, KF0610H1L, KF0610F1H, KF0610F1M, KF0610F1L. All models may have optional suffix "x4x5x6", where "x4", "x5" and "x6" may be A thru Z, 0 thru 9, "-" or blank.

Models JF0515(A)1(B)XXX, JF0515(A)2(B)XXX, JF0615(A)5(C)XXX, JF0615(A)1(D)XXX, JF0615(A)2(D)XXX, JF0620(A)1(D)XXX, JF0620(A)2(D)XXX, JF0625(A)1(F)XXX, JF0625(A)2(E)XXX, JF0625(A)4(F)XXX, JF0825(A)1(D)XXX, JF0825(A)2(C)XXX, JF0825(A)4(G)XXX, JF0925(A)1(I)XXX, JF0925(A)2(D)XXX, JF0925(A)4(I)XXX, JF1225(A)1(D)XXX, JF1225(A)2(D)XXX, JF1225(A)4(F)XXX, where (A) may be B, C or S, (B) may be H, M, L or E, (C) may be H, M, L, F or V, (D) may be U or S, (E) may be T, U or S, (F) may be U, S, H, M, L or E, (G) may be U, S, H, M or L, (H) may be S, H, M or L, (I) may be S, H, M, L or E and "X" may be 0 thru 9, A thru Z, blank or "-". (A1) may be B, C, S, H or F.

Models KF0420(A)2(B)(C), KF1225(A)1(D)(C), where (A) may be B, S, C, F or H, (B) may be L, M, H or S, (D) may be V, E, L, M or H and (C) may be XXX, where X may be 0 thru 9, A thru Z, "-" or blank.

Models LF0825(a)1(c)(f)(g)(h)(i)(j), LF0925(b)1(d)(f)(g)(h)(i)(j) and LF1225(b)1(e)(f)(g)(h)(i)(j) series, where (a) may be S, B or C; (b) may be S or B; (c) may be S, H, M, L or E; (d) may be H, M, L or E; (e) may be H, M, L, E or V; (f) may be "-" or 0 thru 9 or A thru Z; (g) may be 0 thru 4; (h) may be "-" or 0 thru 9 or A thru Z; (i) may be blank, "-" or 0 thru 9 or A thru Z; (j) may be blank, "-" or 0 thru 9 or A thru Z.

AC component fans, Models JA1238(a)(c)(b)(x)(y), JA1238HD(b)(x)(y), KA1238(a)(c)(b)(x)(y) and KA1238HD(b)(x)(y) series, where (a) may be H, M or L; (c) may be 1 or 2; (b) may be B or S; (x) and (y) may be blank, "-", 0~9 or A~Z.

DC Component Fans, Models KF0B10(b)5(r1)(xy)(z), KF0B10(b)1(r1)(xy)(z), KF0410(b)2(r6)(xy)(z), KF0510(b)2(r2)(xy)(z), KF0610(b)5(r3)(xy)(z), KF0615(b)5(r3)(xy)(z), KF0615(b)1(r4)(xy)(z), KF0615(b)2(r4)(xy)(z), KF0620(b)1(r5)(xy)(z), KF0620(b)2(r5)(xy)(z), KF0715(b)1S(xy)(z), KF0715(b)1(r2)(xy)(z), KF0820(b)1(r7)(xy)(z), KF0820(b)2(r7)(xy)(z), KF1225(b)2(r2)(xy)(z), JF0815(b)1(r8)(xy)(z), JF0815(b)2(r8)(xy)(z), JF1238(b)1(r1)(xy)(z), JF1238(b)2(r1)(xy)(z) and JF1238(b)4(r6)(xy)(z) series, where (b) may be S, B, C, H or F; (r1) may be S, H, M, L or E; (r2) may be H, M or L; (r3) may be M, L, E or V; (r4) may be U, S, H, M, L, E or V; (r5) may be S, H, M, L, E or V; (r6) may be S, H, M or L; (r7) may be U, S, H, M, L or E; (r8) may be U, S, H, M or L; (xy) is alphanumeric combination of two digits and/or alphabets, each may be blank, "-", A through Z or 0 through 9; (z) may be blank, "-", A through Z or 0 through 9.

AC component fans, Models JA1225H1(b)(x)(y), JA1225L1(b)(x)(y), JA0925H1(b)(x)(y), JA0838H1(b)(x)(y), JA0825H1(b)(x)(y), JA1225H2(b)(x)(y), JA1225L2(b)(x)(y), JA0925H2(b)(x)(y), JA0838H2(b)(x)(y), JA0825H2(b)(x)(y) series, where (b) may be B or S; (x) and (y) may be blank, "-", 0~9 or A~Z.

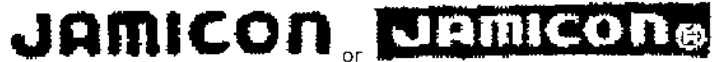

Marking: Company name, "E156480", trademark **JAMICON** or  and model designation.

Last Updated on 2006-12-12

[Questions?](#)

[Notice of Disclaimer](#)

[Page Top](#)

Copyright © 2007 Underwriters Laboratories Inc.®

The appearance of a company's name or product in this database does not in itself assure that products so identified have been manufactured under UL's Follow-Up Service. Only those products bearing the UL Mark should be considered to be Listed and covered under UL's Follow-Up Service. Always look for the Mark on the product.

UL permits the reproduction of the material contained in the Online Certification Directory subject to the following conditions: 1. The Guide Information, Designs and/or Listings (files) must be presented in their entirety and in a non-misleading manner, without any manipulation of the data (or drawings). 2. The statement "Reprinted from the Online Certifications Directory with permission from Underwriters Laboratories Inc." must appear adjacent to the extracted material. In addition, the reprinted material must include a copyright notice in the following format: "Copyright © 2007 Underwriters Laboratories Inc.®"





GPWV8.E156480

Fans, Electric Certified for Canada - Component

Page Bottom

Fans, Electric Certified for Canada - Component

See General Information for Fans, Electric Certified for Canada - Component

KAIMEI ELECTRONIC CORP

E156480

13TH

81 HSIN-TAI-WU RD, SEC 1

HSICHIH, TAIPEI HSIEN 221 TAIWAN

AC fans, Models JA1203811XX, JA1203822XX, where XX is any character; Model JA1738 followed by H2 or H1; Model JA1238 followed by M2, M1, L2 or L1; Model JA1225 followed by L2 or L1; Models JA0825H1(X1)(X2)(X3), JA0825H2(X1)(X2)(X3), JA0838H1(X1)(X2)(X3), JA0838H2(X1)(X2)(X3), JA0925H1(X1)(X2)(X3), JA0925H2(X1)(X2)(X3), JA1225H1(X1)(X2)(X3), JA1225H2(X1)(X2)(X3), JA1225L1(X1)(X2)(X3), JA1225L2(X1)(X2)(X3), JA1238H1(X1)(X2)(X3), JA1238H2(X1)(X2)(X3), JA1238M1(X1)(X2)(X3), JA1238M2(X1)(X2)(X3), JA1238L1(X1)(X2)(X3), JA1238L2(X1)(X2)(X3), JA1738H1(X1)(X2)(X3), JA1738H2(X1)(X2)(X3), JA1751H1(X1)(X2)(X3), JA1751H2(X1)(X2)(X3), JA0938H1(X1)(X2)(X3), JA0938H2(X1)(X2)(X3), JA2589H1(X1)(X2)(X3), JA2589H2(X1)(X2)(X3), JA1538H1(X1)(X2)(X3), JA1538H2(X1)(X2)(X3), JA1538M1(X1)(X2)(X3), JA1538M2(X1)(X2)(X3), JA1538L1(X1)(X2)(X3), JA1538L2(X1)(X2)(X3), LA1238H1(X1)(X2)(X3), LA1238H2(X1)(X2)(X3), LA1738M1(X1)(X2)(X3), LA1238M2(X1)(X2)(X3), LA1238L1(X1)(X2)(X3), LA1738L2(X1)(X2)(X3), LA0925H1(X1)(X2)(X3), LA0925H2(X1)(X2)(X3), LA0825H1(X1)(X2)(X3), LA0825H2(X1)(X2)(X3), where (X1), (X2), (X3) may be 0 thru 9, A thru Z, "-" or blank.

Models MA0825H2Bzz, MA0825H2Szz, MA0825M2Bzz, MA0825M2Szz, MA0838H2Bzz, MA0838H2Szz, MA0838M2Bzz, MA0838M2Szz, MA0925H2Bzz, MA0925H2Szz, MA0925M2Bzz, MA0925M2Szz, MA0938H2Bzz, MA0938H2Szz, MA0938M2Bzz, MA0938M2Szz, MA1225H2Bzz, MA1225H2Szz, MA1225M2Bzz, MA1225M2Szz, KA1338H2Bzz, KA1338H2Szz, KA1338M2Bzz, KA1338M2Szz, KA1338L2Bzz, KA1338L2Szz, MA1338H2Bzz, MA1338H2Szz, MA1338M2Bzz, MA1338M2Szz, MA2260H2Bzz, MA0825H1Bzz, MA0825H1Szz, MA0825M1Bzz, MA0825M1Szz, MA0838H1Bzz, MA0838H1Szz, MA0838M1Bzz, MA0838M1Szz, MA0925H1Bzz, MA0925H1Szz, MA0925M1Bzz, MA0925M1Szz, MA0938H1Bzz, MA0938H1Szz, MA0938M1Bzz, MA0938M1Szz, KA0938H1Bzz, KA0938H1Szz, KA0938M1Bzz, KA0938M1Szz, MA1225H1Bzz, MA1225H1Szz, MA1225M1Bzz, MA1225M1Szz, KA1338H1Bzz, KA1338H1Szz, KA1338M1Bzz, KA1338M1Szz, KA1338L1Bzz, KA1338L1Szz, MA1338H1Bzz, MA1338H1Szz, MA1338M1Bzz, MA1338M1Szz, MA2260H1Bzz.

Models JA1751H1, JA1751H2, JA1238H1, JA1238H2, JA1238-1H1, JA1238-1H2, JA1225H1, JA1225H2, JA0925H1, JA0925H2, JA0838H1, JA0838H2, JA0825H1, JA0825H2.

Model KAX (A) (B) X1 and/or X2, where X may be 0825, 0838, 0925, 1225, 1238 or 1751, (A) may be H1, H2, M1, M2, L1 or L2, (B) may be B or S and X1, X2 may be 0 thru 9, A thru Z, blank or "-"; Model MAX (A) (B) X1 and/or X2, where X may be 1238, 1538, 1738, 1751, 1755 or 2589, (A) may be H1, H2, M1 or M2, (B) may be B, S and X1, X2 may be 0 thru 9, A thru Z or "-".

DC fans Models JF0207, JF0307, JF0407 followed by B or S, followed by -1HX, -1LX, -1MX, -5HX, -5LM or -5MX; Model JF0210 followed by B, C or S, followed by -5LXXX; Model JF0410 followed by B, C or S, followed by -1XXX, -1MXXX, -1HXXX or -5MXXX; Model JF0413 followed by B, C or S, followed by -1MXXX or -1HXXX; Model JF0512 followed by B, C or S, followed by -1LXXX or -1MXXX; Model JF0615 followed by B, C or S, followed by -1HXXX, -1LXXX or -1MXXX, -1EXXX, -1VXXX; Model JF0620 followed by B, C or S, followed by 1VXXX, -1EXXX, 1LXXX, 1MXXX, 1HXXX, -2VXXX, -2EXXX, -2LXXX, -2HXXX or -2MXXX; Model JF0625 followed by B, C or S, followed by -1VXXX, -1EXXX, -1LXXX, -1MXXX, 1HXXX, -2VXXX, -2EXXX, -2LXXX, -2MXXX or -2HXXX; Model JF0825 followed by B, C or S, followed by -1EXXX, -1LXXX, -1MXXX, -1HXXX, -2EXXX, -2LXXX, -2MXXX or -2HXXX; where "X" may be 0 thru 9, A thru Z, "-" or blank; Model JF0925 followed by B, C or S, followed by 1EXXX, 1LXXX, 1MXXX, -1HXXX, -2EXXX, -2LXXX, 2MXXX or -2HXXX; Model JF1225 followed by B, C or S, followed by -1EXXX -1LXXX, -1MXXX, -1HXXX, -2EXXX, -2LXXX, -2MXXX or -2HXXX; Model JH041051.

Models JF0210, JF0410, JF0510 followed by B or S, may be followed by 1H, 1M, 1L, 5L, 5M.

Model JF0615(X)2(Y)XXX, where (X) may be S, B or C and (Y) may be H, M, L, E or V.

Models JF0210(X)1H(Y), JF0210(X)1M(Y), JF0210(X)5H(Y), JF0210(X)5L(Y), JF0210(X)5M(Y), where (X) may be B, C or S and (Y) may be 0 thru 9, A thru Z or blank.

Models JF0310(X)1H(Y), JF0310(X)1L(Y), JF0310(X)1M(Y), JF0310(X)5H(Y), JF0310(X)5L(Y), JF0310(X)5M(Y), where (X) may

be B, C or S and (Y) may be 0 thru 9, A thru Z or blank.

Models JF0A08(X)5H(Y), JF0A08(X)5L(Y), JF0A08(X)5M(Y), where (X) may be B, C or S and (Y) may be 0 thru 9, A thru Z or blank.

Models JF0B10(X)1H(Y), JF0B10(X)1L(Y), JF0B10(X)1M(Y), JF0B10(X)5H(Y), JF0B10(X)5L(Y), JF0B10(X)5M(Y), where (X) may be B, C or S and (Y) may be 0 thru 9, A thru Z or blank.

Model JF1751(X)4S(Y), where (X) may be B, C or S and (Y) may be 0 thru 9, A thru Z or blank.

Models KF0210S5L, KF0210S5M, KF0210S5H, KF0210B5L, KF0210B5M, KF0210B5H, KF0210B5LD, KF0210B5MD, KF0210B5HD, KF0310S5L, KF0310S5M, KF0310S5H, KF0310B5L, KF0310B5M, KF0310B5H, KF0310B5LD, KF0310B5MD, KF0310B5HD, KF0410S5L, KF0410S5M, KF0410S5H, KF0410B5L, KF0410B5M, KF0410B5H, KF0410B5LD, KF0410B5MD, KF0410B5HD, KF0306S1M, KF0306S1H, KF0306B1M, KF0306B1H, KF0406S1M, KF0406S1H, KF0406B1M, KF0406B1H, KF0409S1L, KF0409S1M, KF0409S1H, KF0409B1L, KF0409B1M, KF0409B1H, KF0409B1LD, KF0409B1MD, KF0409B1HD, KF0510S1L, KF0510S1M, KF0510S1H, KF0510B1L, KF0510B1M, KF0510B1H, KF0510B1LD, KF0510B1MD, KF0510B1HD, KB3508S1M, KB3508S1H, KB3508B1M, KB3508B1H, KB4509S1M, KB4509S1H, KB4509B1M, KB4509B1H, KF0410B5M, KF0410B5H, KF0410B5LD, KF0410B5MD, KF0410B5HD, KF0306S5M, KF0306S5H, KF0306B5M, KF0306B5H, KF0406S5M, KF0406S5H, KF0406B5M, KF0406B5H, KF0409S5L, KF0409S5M, KF0409S5H, KF0409B5L, KF0409B5M, KF0409B5H, KF0409B5LD, KF0409B5MD, KF0409B5HD, KF0509S5L, KF0509S5M, KF0509S5H, KF0509B5L, KF0509B5M, KF0509B5H, KF0509B5LD, KF0509B5MD, KF0509B5HD, KB3508S5M, KB3508S5H, KB3508B5M, KB3508B5H, KB4509S5M, KB4509S5H, KB4509B5M, KB4509B5H, KF0210S1L, KF0210S1M, KF0210S1H, KF0210B1L, KF0210B1M, KF0210H5L, KF0210H5M, KF0210H5H, KF0210F5L, KF0210F5M, KF0210F5H, KF0210H1L, KF0210H1M, KF0210H1H, KF0210F1L, KF0210F1M, KF0210F1H, KF0310H5L, KF0310H5M, KF0310H5H, KF0310F5L, KF0310F5M, KF0310F5H, KF0310H1L, KF0310H1M, KF0310H1H, KF0310F1L, KF0310F1M, KF0310F1H, KF0410H1L, KF0410H1M, KF0410H1H, KF0410F1L, KF0410F1M, KF0410F1H, KF0410H5L, KF0410H5M, KF0410H5H, KF0410F5L, KF0410F5M, KF0410F5H, KF0510C1H, KF0510H1L, KF0510H1M, KF0510H1H, KF0510F1L, KF0510F1M, KF0510F1H. All models may have optional suffix "x4x5x6", where "x4", "x5", and "x6" may be A-Z, 0-9, "-" or blank.

Model KF0xyz, where x may be 420, 515 or 610, y may be B1, B2, B5, S1, S2 or S5 and z may be H, HC, HD, HS, L, LC, LD, LS, M, MC, MD or MS; Model KF123xyz, where x may be 2 or 8, y may be B1, B2, B5, S1, S2 or S4 and z may be H, HA, L, LA, M or MA; Model MF0xyz where x may be 410 or 510, y may be B1, B5, S1 or S5 and z may be H, HC, HD, HS, L, LC, LD, LS, M, MC, MD or MS.

Models KF0210S5L, KF0210S5M, KF0210S5H, KF0210B5L, KF0210B5M, KF0210B5H, KF0210C5L, KF0210C5M, KF0210C5H, KF0210S1L, KF0210S1M, KF0210S1H, KF0210B1L, KF0210B1M, KF0210B1H, KF0210C1L, KF0210C1M, KF0210C1H, KF0310S5L, KF0310S5M, KF0310S5H, KF0310B5L, KF0310B5M, KF0310B5H, KF0310C5L, KF0310C5M, KF0310C5H, KF0310S1L, KF0310S1M, KF0310S1H, KF0310B1L, KF0310B1M, KF0310B1H, KF0310C1L, KF0310C1M, KF0310C1H, KF0410S1L, KF0410S1M, KF0410S1H, KF0410B1L, KF0410B1M, KF0410B1H, KF0410C1L, KF0410C1M, KF0410C1H, KF0410S5L, KF0410S5M, KF0410S5H, KF0410B5L, KF0410B5M, KF0410B5H, KF0410C5L, KF0410C5M, KF0410C5H, KF0510S1L, KF0510S1M, KF0510S1H, KF0510B1L, KF0510B1M, KF0510B1H, KF0510C1L, KF0510C1M, KF0510C1H. All models may have optional suffix "x4x5x6", where "x4", "x5" and "x6" may be A thru Z, 0 thru 9, "-" or blank.

Models KF0510S5L, KF0510S5M, KF0510S5H, KF0510C5L, KF0510C5M, KF0510C5H, KF0510B5L, KF0510B5M, KF0510B5H, KF0515S5H, KF0515S5M, KF0515S5L, KF0515C5L, KF0515C5M, KF0515C5H, KF0515B5L, KF0515B5M, KF0515B5H, KF0509B1H, KF0509B1L, KF0509B1M, KF0509S1H, KF0509S1L, KF0509S1M, KF0509C1H, KF0509C1L, KF0509C1M, KF0515S1H, KF0515S1M, KF0515S1H, KF0515C1L, KF0515C1M, KF0515C1H, KF0515B1L, KF0515B1M, KF0515B1H, KF0625S1L, KF0625S1M, KF0625S1H, KF0625C1L, KF0625C1M, KF0625C1H, KF0625B1L, KF0625B1M, KF0625B1H, KF0510F5L, KF0510F5M, KF0510F5H, KF0510H5L, KF0510H5M, KF0510H5H. All models may have optional suffix "x4x5x6", where "x4", "x5" and "x6" may be A thru Z, 0 thru 9, "-" or blank.

Models KF0407C1H, KF0407S1H, KF0407C1M, KF0407S1M, KF0407C5H, KF0407S5H, KF0407C5M, KF0407S5M, KF0C07C1H, KF0C07S1H, KF0C07C1M, KF0C07S1M, KF0C07C5H, KF0C07S5H, KF0C07C5M, KF0C07S5M, KF0420B1L, KF0420S1L, KF0420B1M, KF0420S1M, KF0420B1H, KF0420S1H, KF0420B5L, KF0420S5L, KF0420B5M, KF0420S5M, KF0420B5H, KF0420S5H, KF0610S1H, KF0610C1H, KF0610B1H, KF0610C1M, KF0610B1M, KF0610S1M, KF0610C1L, KF0610B1L, KF0610S1L, KF0420C1L, KF0420H1L, KF0420F1L, KF0420C1M, KF0420H1M, KF0420F1M, KF0420C1H, KF0420H1H, KF0420F1H, KF0420C5L, KF0420H5L, KF0420F5L, KF0420C5M, KF0420H5M, KF0420F5M, KF0420C5H, KF0420H5H, KF0420F5H, KF0610H1H, KF0610H1M, KF0610H1L, KF0610F1H, KF0610F1M, KF0610F1L. All models may have optional suffix "x4x5x6", where "x4", "x5" and "x6" may be A thru Z, 0 thru 9, "-" or blank.

Models JF0515(A)1(B)XXX, JF0515(A)2(B)XXX, JF0615(A)5(C)XXX, JF0615(A)1(D)XXX, JF0615(A)2(D)XXX, JF0620(A)1(D)XXX, JF0620(A)2(D)XXX, JF0625(A)1(E)XXX, JF0625(A)2(E)XXX, JF0625(A)4(F)XXX, JF0825(A)1(D)XXX, JF0825(A)2(E)XXX, JF0825(A)4(G)XXX, JF0925(A)1(D)XXX, JF0925(A)2(D)XXX, JF0925(A)4(I)XXX, JF1225(A)1(D)XXX, JF1225(A)2(D)XXX, JF1225(A)4(F)XXX, where (A) may be B, C or S, (B) may be H, M, L or F, (C) may be H, M, L, E or V, (D) may be U or S, (E) may be T, U or S, (F) may be U, S, H, M, L or E, (G) may be U, S, H, M or L, (H) may be S, H, M or L, (I) may be S, H, M, L or E and "X" may be 0 thru 9, A thru Z, blank or "-", (A) may be B, C, S, H or F.

Models KF0420(A)2(B)(C), KF1225(A)1(D)(C), where (A) may be B, S, C, F or H, (B) may be L, M, H or S, (D) may be V, E, L, M or H and (C) may be XXX, where X may be 0 thru 9, A thru Z, "-" or blank.

Models LF0825(a)1(c)(f)(g)(h)(i)(j), LF0925(b)1(d)(t)(g)(h)(i)(j) and LF1225(b)1(e)(f)(g)(h)(i)(j) series, where (a) may be S, B or C; (b) may be S or B; (c) may be S, H, M, L or F; (d) may be H, M, L or E; (e) may be H, M, L, E or V; (f) may be "-" or 0

thru 9 or A thru Z; (g) may be 0 thru 4; (h) may be "-" or 0 thru 9 or A thru Z; (i) may be blank, "-" or 0 thru 9 or A thru Z; (j) may be blank, "-" or 0 thru 9 or A thru Z.

AC component fans, Models JA1238(a)(c)(b)(x)(y), JA1238HD(b)(x)(y), KA1238(a)(c)(b)(x)(y) and KA1238HD(b)(x)(y) series, where (a) may be H, M or L; (c) may be 1 or 2; (b) may be B or S; (x) and (y) may be blank, "-", 0~9 or A~Z.

DC Component Fans, Models KF0810(b)5(r1)(xy)(z), KF0810(b)1(r1)(xy)(z), KF0410(b)2(r6)(xy)(z), KF0510(b)2(r2)(xy)(z), KF0610(b)5(r3)(xy)(z), KF0615(b)5(r3)(xy)(z), KF0615(b)1(r4)(xy)(z), KF0615(b)2(r4)(xy)(z), KF0620(b)1(r5)(xy)(z), KF0620(b)2(r5)(xy)(z), KF0715(b)1S(xy)(z), KF0715(b)1(r2)(xy)(z), KF0820(b)1(r7)(xy)(z), KF0820(b)2(r7)(xy)(z), KF1225(b)2(r7)(xy)(z), JF0815(b)1(r8)(xy)(z), JF0815(b)2(r8)(xy)(z), JF1238(b)1(r1)(xy)(z), JF1238(b)2(r1)(xy)(z) and JF1238(b)4(r6)(xy)(z) series, where (b) may be S, B, C, H or F; (r1) may be S, H, M, L or E; (r2) may be H, M or L; (r3) may be M, I, F or V; (r4) may be U, S, H, M, L, E or V; (r5) may be S, H, M, L, E or V; (r6) may be S, H, M or L; (r7) may be U, S, H, M, L or E; (r8) may be U, S, H, M or L; (xy) is alphanumeric combination of two digits and/or alphabets, each may be blank, "-", A through Z or 0 through 9; (z) may be blank, "-", A through Z or 0 through 9.

AC component fans, Models JA1225H1(b)(x)(y), JA1225L1(b)(x)(y), JA0925H1(b)(x)(y), JA0838H1(b)(x)(y), JA0825H1(b)(x)(y), JA1225H2(b)(x)(y), JA1225L2(b)(x)(y), JA0925H2(b)(x)(y), JA0838H2(b)(x)(y), JA0825H2(b)(x)(y) series, where (b) may be B or S; (x) and (y) may be blank, "-", 0~9 or A~Z.



Marking: Company name, model designation and Recognized Component Mark for Canada, *
Last Updated on 2006-12-12

[Questions?](#)

[Notice of Disclaimer](#)

[Page Top](#)

Copyright © 2007 Underwriters Laboratories Inc.®

The appearance of a company's name or product in this database does not in itself assure that products so identified have been manufactured under UL's Follow-Up Service. Only those products bearing the UL Mark should be considered to be Listed and covered under UL's Follow-Up Service. Always look for the Mark on the product.

UL permits the reproduction of the material contained in the Online Certification Directory subject to the following conditions: 1. The Guide Information, Designs and/or Listings (files) must be presented in their entirety and in a non-misleading manner, without any manipulation of the data (or drawings). 2. The statement "Reprinted from the Online Certifications Directory with permission from Underwriters Laboratories Inc." must appear adjacent to the extracted material. In addition, the reprinted material must include a copyright notice in the following format: "Copyright © 2007 Underwriters Laboratories Inc.®"





Appendix to TÜV type approved Certificate No.: R 9552030

Kind of equipment : Component DC Fan
 Report number : 09562037 006

Modell	Leistungsfähigkeit	Modell	Leistungsfähigkeit
JF0825S1HXXX	12Vdc, 0.19A	JF0825S2HXXX	24Vdc, 0.15A
JF0825B1HXXX	12Vdc, 0.19A	JF0825B2HXXX	24Vdc, 0.15A
JF0825C1HXXX	12Vdc, 0.19A	JF0825C2HXXX	24Vdc, 0.15A
JF0825S1MXXX	12Vdc, 0.15A	JF0825S2MXXX	24Vdc, 0.13A
JF0825B1MXXX	12Vdc, 0.15A	JF0825B2MXXX	24Vdc, 0.13A
JF0825C1MXXX	12Vdc, 0.15A	JF0825C2MXXX	24Vdc, 0.13A
JF0825S1LXXX	12Vdc, 0.10A	JF0825S2LXXX	24Vdc, 0.10A
JF0825B1LXXX	12Vdc, 0.10A	JF0825B2LXXX	24Vdc, 0.10A
JF0825C1LXXX	12Vdc, 0.10A	JF0825C2LXXX	24Vdc, 0.10A
JF0825S1EXXX	12Vdc, 0.06A	JF0825S2EXXX	24Vdc, 0.05A
JF0825B1EXXX	12Vdc, 0.06A	JF0825B2EXXX	24Vdc, 0.05A
JF0825C1EXXX	12Vdc, 0.06A	JF0825C2EXXX	24Vdc, 0.05A
JF0925S1HXXX	12Vdc, 0.35A	JF0925S2HXXX	24Vdc, 0.19A
JF0925B1HXXX	12Vdc, 0.35A	JF0925B2HXXX	24Vdc, 0.19A
JF0925C1HXXX	12Vdc, 0.35A	JF0925C2HXXX	24Vdc, 0.19A
JF0925S1MXXX	12Vdc, 0.20A	JF0925S2MXXX	24Vdc, 0.15A
JF0925B1MXXX	12Vdc, 0.20A	JF0925B2MXXX	24Vdc, 0.15A
JF0925C1MXXX	12Vdc, 0.20A	JF0925C2MXXX	24Vdc, 0.15A
JF0925S1LXXX	12Vdc, 0.16A	JF0925S2LXXX	24Vdc, 0.13A
JF0925B1LXXX	12Vdc, 0.16A	JF0925B2LXXX	24Vdc, 0.13A
JF0925C1LXXX	12Vdc, 0.16A	JF0925C2LXXX	24Vdc, 0.13A
JF0925S1EXXX	12Vdc, 0.10A	JF0925S2EXXX	24Vdc, 0.07A
JF0925B1EXXX	12Vdc, 0.10A	JF0925B2EXXX	24Vdc, 0.07A
JF0925C1EXXX	12Vdc, 0.10A	JF0925C2EXXX	24Vdc, 0.07A
JF1225S1HXXX	12Vdc, 0.30A	JF1225S2HXXX	24Vdc, 0.25A

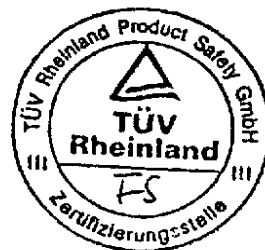

F. Müller

Zertifikat

Certificate



Zertifikat Nr. *Certificate No.* Blatt *Page*
R 09552030 0018

Ihr Zeichen <i>Client Reference</i>	Unser Zeichen <i>Our Reference</i>	Ausstellungsdatum <i>Date of Issue</i>	<i>(day/mo/yr)</i>
KL230506/DTI	ZTW1-LYA- 09562037 010	27.06.2006	

Genehmigungsinhaber *License Holder*
Kaimei Electronic Corp.
13th Fl., No. 81
Sec. 1, Hsin-Tai-Wu Rd.
Hsichih, Taipei Hsien 221
Taiwan

Fertigungsstätte *Manufacturing Plant*
Kaimei Electronic (HK), Ltd.
10th Industry Area
2nd Road, Donghuan, Long Hua
Shenzhen City, Guangdong
P.R. China

Prüfzeichen *Test Mark*

Geprüft nach *Tested acc. to*
EN 60950-1:2001+A11

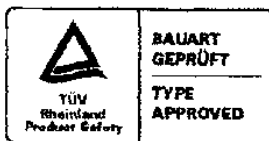

Zertifiziertes Produkt *(Geräteidentifikation)*
Certified Product (Product Identification)

Lizenzentgelte - Einheit
License Fee - Unit

Ventilator (Component DC Fan)

wie Blatt (as page) 01

Änderung für Bezeichnung 1) JF0625X1X2X3XXX
(Change for Type Designation) 2) JF0825X1X2X3XXX
3) JF0925X1X2X3XXX
4) JF1225X1X2X3XXX

Bezeichnung : 1) JF0625X1X2X3XXX (JAMICON)
(Type Designation) 2) JF0825X1X2X3XXX (JAMICON)
3) JF0925X1X2X3XXX (JAMICON)
4) JF1225X1X2X3XXX (JAMICON)

X1 kann sein (can be) : B, S, C, H oder (or) F
X2 kann sein (can be) : 1 oder (or) 2
X3 kann sein (can be) : 1) H, M, L, E oder (or) V
2), 3), 4) H, M, L oder (or) E
X kann sein (can be) : 0-9, A-Z, - oder (or)
freibleibend (blank)

Hinweis : Dieses Ausweisblatt ersetzt R 9552030, Blatt
018 vom 22.06.2006. (Remarks: This license sheet replaces
R 9552030, sheet 018 dated 22.06.2006)

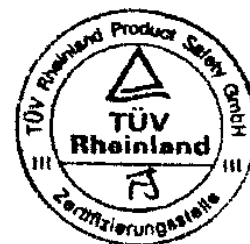

ANLAGE (Appendix): 1.6

Dem Zertifikat liegt unsere Prüf- und Zertifizierungsordnung zugrunde.
Das Produkt entspricht den o.g. Anforderungen, die Herstellung wird überwacht.
This certificate is based on our Testing and Certification Regulation. The product
fulfills above-mentioned requirements, the production is subject to surveillance.

TÜV Rheinland Product Safety GmbH, Am Grauen Stein, D-51105 Köln

Tel.: (+49/221) 8 06 - 13 71 Fax: (+49/221) 8 06 - 39 35 e-mail: Athoff@de.tuv.com

Zertifizierungsstelle

Dipl.-Ing. F. Stöckel



SPORTON LAB.

Certificate No: EC2D2008-01

CERTIFICATE

- **EQUIPMENT: DC FAN**
MODEL NO. : JFX1X2X3X4X5X6X7X8, KFX1X2X3X4X5X6X7X8
APPLICANT : Kaimei Electronic Corp.
13th Fl., No. 81, Sec. 1, Hsin Tai Wu Road, Hsichih,
Taipei, Taiwan, R.O.C.



I HEREBY CERTIFY THAT:

THE MEASUREMENTS SHOWN IN THIS TEST REPORT WERE MADE IN ACCORDANCE WITH THE PROCEDURES GIVEN IN EUROPEAN COUNCIL DIRECTIVE 89/336/EEC. THE EQUIPMENT WAS PASSED THE TEST PERFORMED ACCORDING TO EUROPEAN STANDARD EN 55022:1998/A1:2000/A2:2003 Class B, EN 61000-3-2:2000/A1:2001, EN 61000-3-3:1995/A1:2001 and EN 55024:1998/A1:2001/A2:2003 (IEC 61000-4-2:1995/A2:2000, IEC 61000-4-3:2002, IEC 61000-4-4:1995/A2:2001, IEC 61000-4-5:1995/A1:2000, IEC 61000-4-6:1996/A1:2000, IEC 61000-4-8:1993/A1:2000, IEC 61000-4-11:1994/A1:2000). THE TEST WAS CARRIED OUT ON Jan. 11, 2007 AT SPORTON INTERNATIONAL INC. LAB.

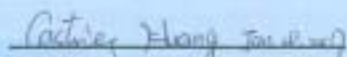
Castries Huang
Supervisor

SPORTON INTERNATIONAL INC. 6F, No.106, Sec.1, Hsin Tai Wu Rd., Hsi Chih, Taipei Hsien, Taiwan, R.O.C.

ACCORDING TO EUROPEAN STANDARD
EN 55022:1998/A1:2000/A2:2003 Class B,
EN 61000-3-2:2000/A1:2001, EN 61000-3-3:1995/A1:2001 and
EN 55024:1998/A1:2001/A2:2003 (IEC 61000-4-2:1995/A2:2000,
IEC 61000-4-3:2002, IEC 61000-4-4:1995/A2:2001,
IEC 61000-4-5:1995/A1:2000, IEC 61000-4-6:1996/A1:2000,
IEC 61000-4-8:1993/A1:2000, IEC 61000-4-11:1994/A1:2000).

More detail information of Model NO.:

X1 means for Width x Width = 02, 03, 04, 05, 06, 07, 08, 09, 0A, 0B, 0C, 12, 15

Where 02=25x25, 03=30x30, 04=40x40, 05=50x50, 06=60x60, 07=70x70, 08=80x80,
09=92x92, 0A=20x20, 0B=35x35, 0C=45x45, 12=120x120, 15= ϕ 172 or 172x150 mm

X2 means for thickness = 06, 07, 09, 10, 12, 15, 20, 25 or 25.4, 32, 38, 51

Where 06= 6, 07=7, 09=9 or 10, 10= 10, 12=12, 15=15, 20=20, 25= 25 or 25.4, 32=32,
38=38, 51=51 mm

Where the cross list for X1&X2 as the following:

0A10, 0206, 0207, 0210, 0306, 0307, 0310, 0B06, 0B07, 0B10, 0406, 0407, 0409, 0410,
0412, 0415, 0420, 0425, 0C07, 0C10, 0509, 0510, 0512, 0515, 0520, 0525, 0610, 0615,
0620, 0625, 0638, 0710, 0715, 0720, 0725, 0815, 0820, 0825, 0832, 0838, 0925, 0932, 0938,
1225, 1232, 1238, 1738, 1751

X3 means for bearing type = S, B, H, C

Where S=Sleeve, B= 2 Ball, C= 1Ball or 1Ball+Sleeve

X4 means for rated voltage =1 (12V), 2 (24V), 3 (32V), 4(48V), 5(5V), A(3V), B (25.5V),
C(42V), D(18V), E(15V)

X5 means for rotation speed =T, U, S, H, M, L, E, V or 7, 6, 5, 4, 3, 2, 1, 0.

Where T or 7 means speed higher than U or 6 speed code,

U or 6 means speed higher than S or 5 speed code,

S or 5 means speed higher than H or 4 speed code,

H or 4 means Standard-high speed code,

M or 3 means Middle speed code.,

L or 2 means Low speed code,

E or 1 means speed lower than L speed code,

V or 0 means speed lower than E speed code.

X6, X7, X8 means the internal code to distinguish the wiring, frame and blade type or the
dimension of the screw hole and or the color of the above material and also for special
printing characters on the label requested by the client.

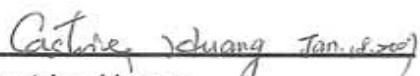
Castries Huang
Supervisor